

A Study of Stress Corrosion Cracking by High-Speed AFM

Stacy Moore, Tomas Martin, Robert Burrows, Loren Picco, Tom Scott, and Oliver Payton

University of Bristol and The National Nuclear Laboratory

EUROCORR 2019 Seville

bristol.ac.uk

High-Speed AFM

- ▶ AFMs build up **topographic maps** of a sample surface by monitoring the mechanical response of a sharp probe at the end of a cantilever as it moves over the surface in a raster pattern.
- ▶ **High-resolution imaging** of surface microstructures, and the measuring mechanical properties at nanometre scales.

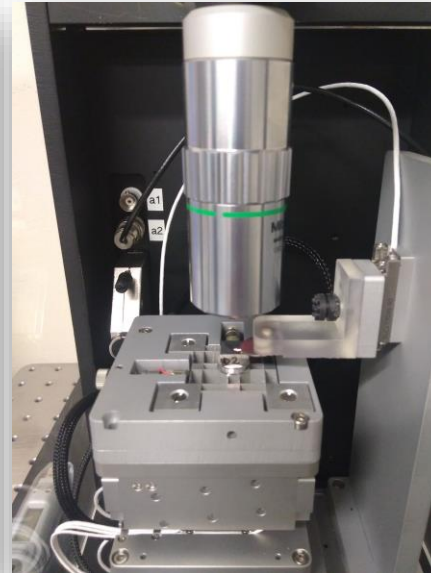
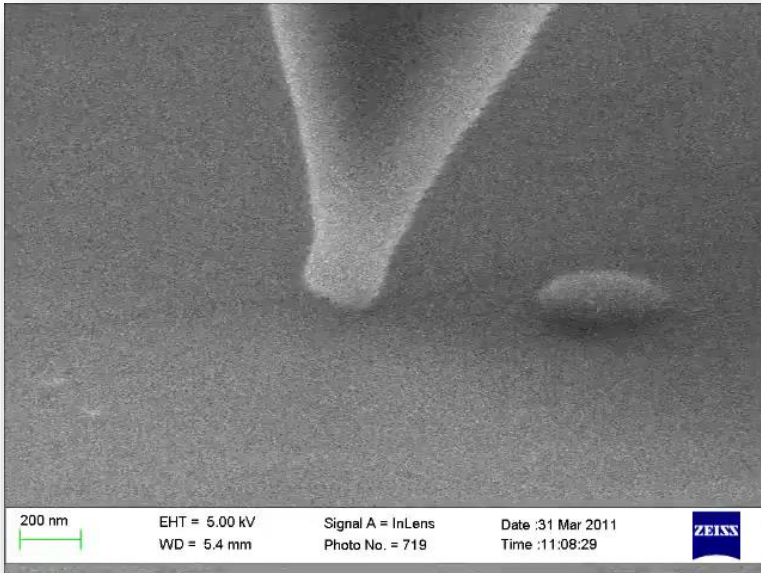
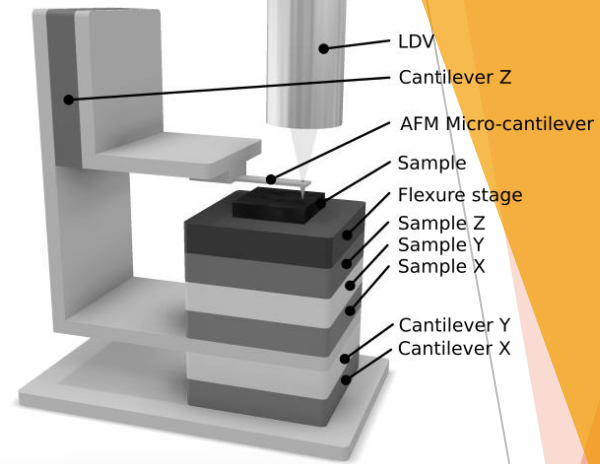

High-Speed AFM

- ▶ The contact mode HS-AFM invented at the University of Bristol and developed at Bristol Nano Dynamics Ltd. is **orders of magnitude faster** than conventional AFMs.
- ▶ Subatomic height resolution and nanometre-scale lateral resolution.
- ▶ Able to image in **ambient or liquid** environments for *in situ* experiments.

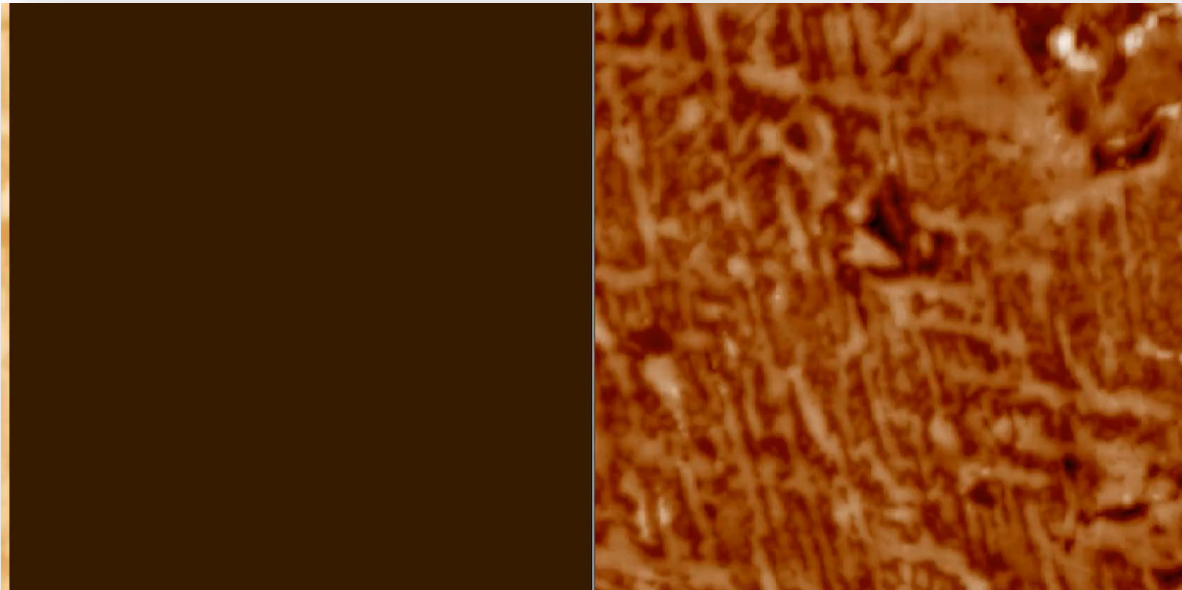
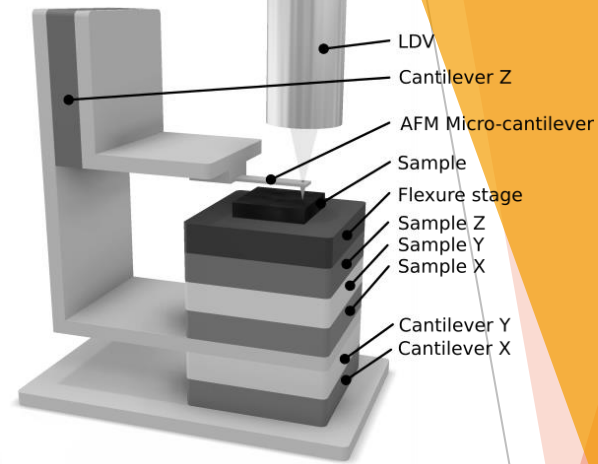

High-Speed AFM

- ▶ Collects **2 million pixels per second**.
- ▶ Frame rates **up to 1000 fps** have been achieved (though typically used at under 10 fps to maintain resolution).
- ▶ Can image **1 mm² with 4 nm pixel size in under a day**.

This is equivalent to imaging the whole of Seville to under 6 cm resolution! (This would take a conventional AFM approximately 1.4 years of continuous imaging.)

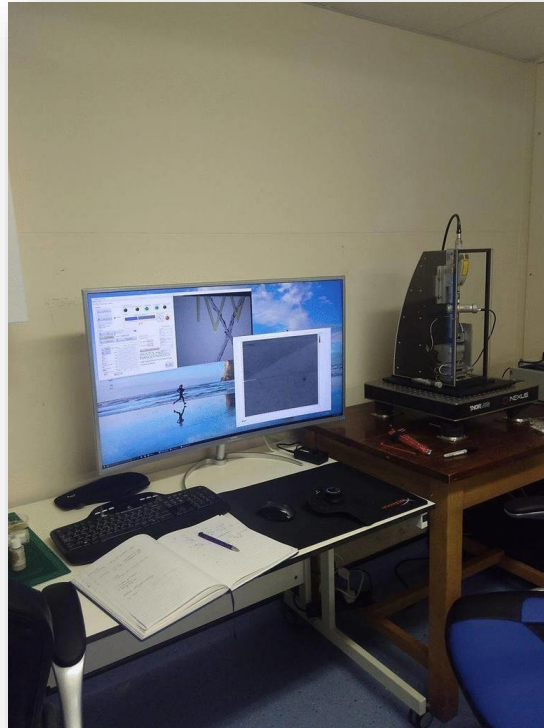

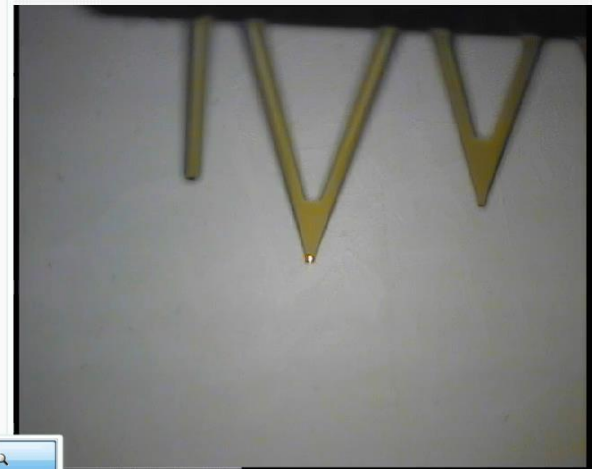
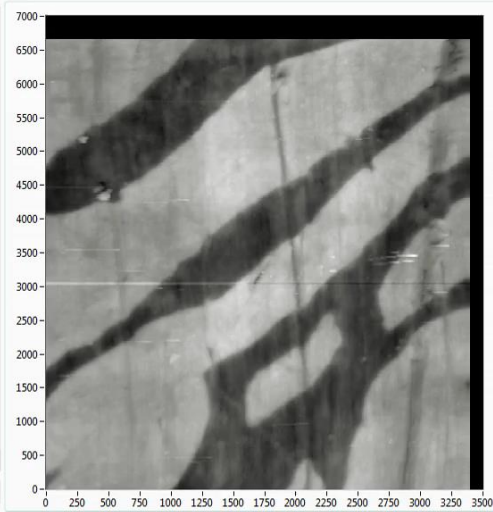
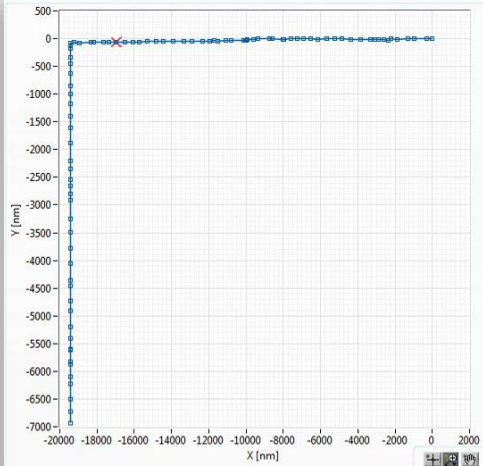

Relative Route Current

CAHS-AFM Data\2017-02-16 - 16.03.05_Middle_done.hsafm

Drag and drop
.hsafm files
here to open

BRISTOL
NANODYNAMICS

Every other frame

Frame:

Playback Rate:

Plot: Displacement

Display: Trace

Transform: flip x

Flattening: SS + FS Flatten

Scale 3d:

3d Lighting On Export Gwyddion file

Greyscale

Number of Channels:

Frame rate:

Data Calibrated

X Pixel to nm:

Y Pixel to nm:

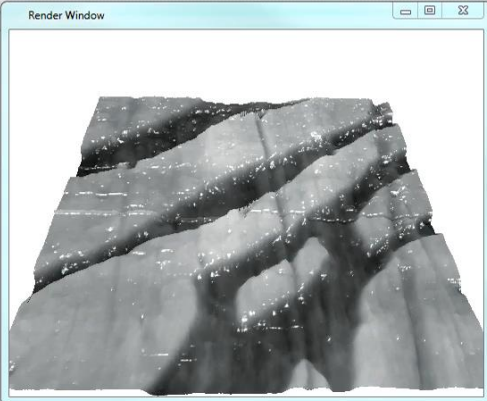

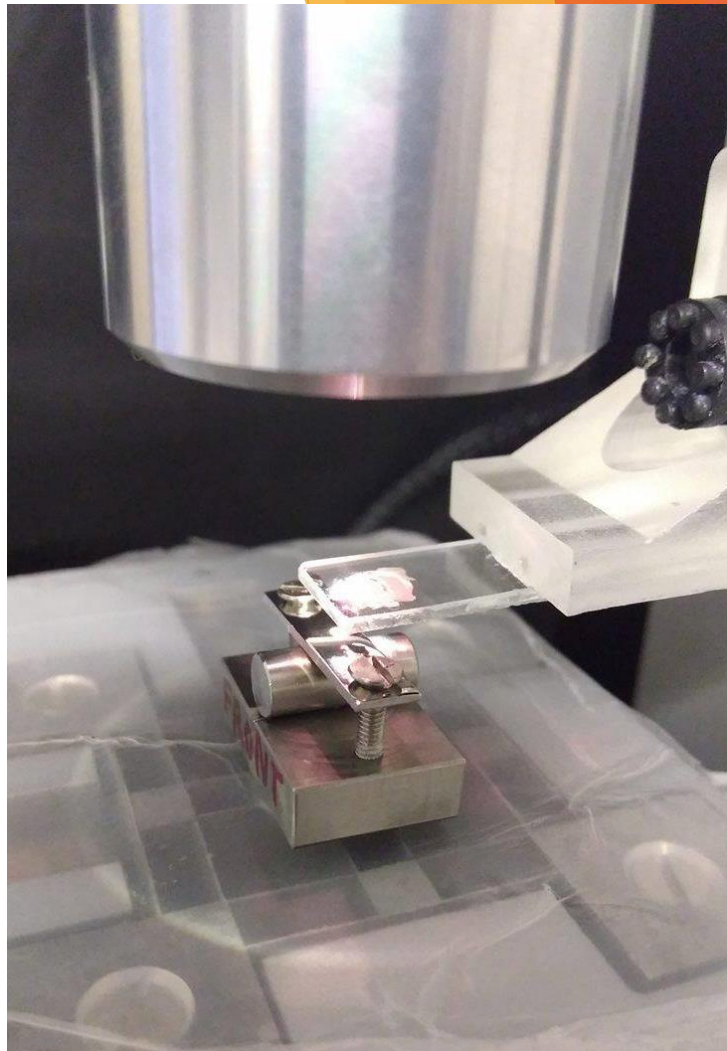
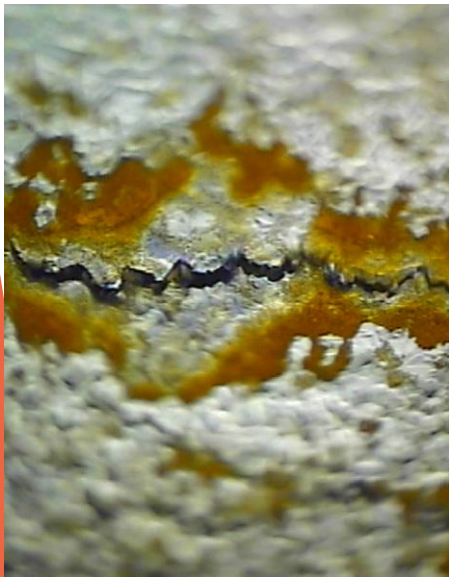
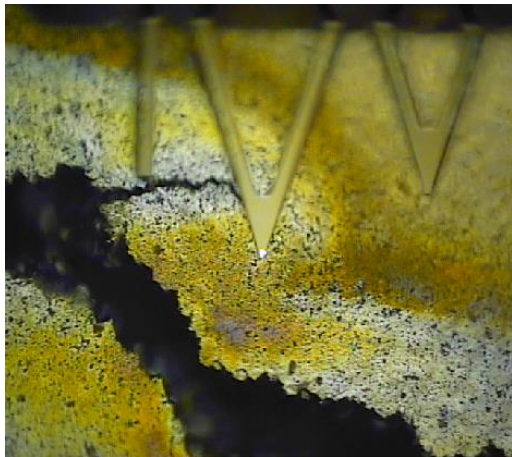
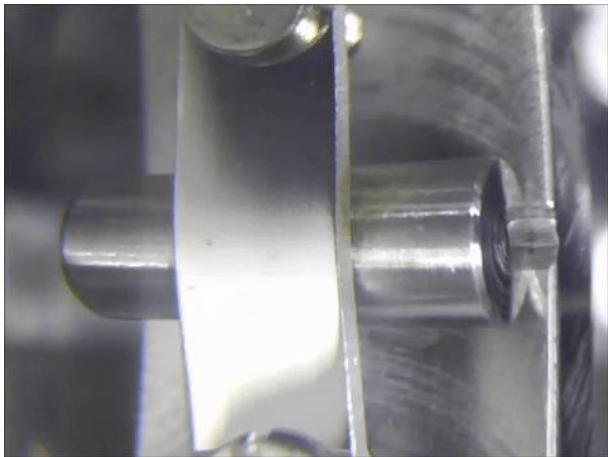

Motivation

- ▶ **Metals and alloys** are widely used in the nuclear power industry.
- ▶ A significant number of structural component failure events in the nuclear industry occur as a result of **corrosion**.
- ▶ Corrosion can be **affected by many factors**, both internal and external and as such is considered a highly complex process.

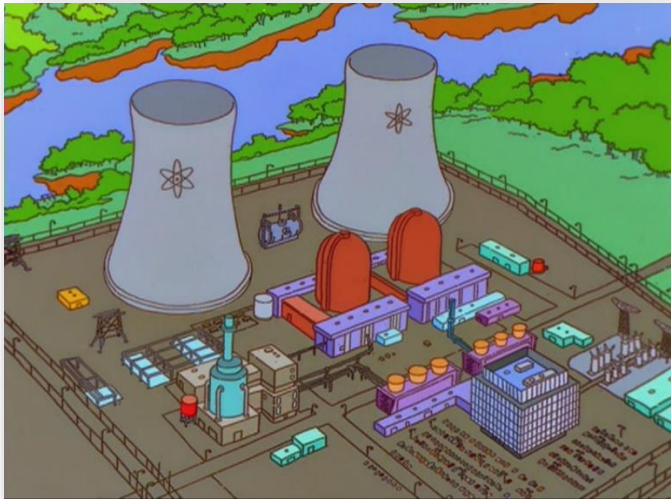

- ▶ Stainless steel fuel cladding can become **sensitised** after irradiation and heating.
- ▶ This can lead to susceptibility to **localised corrosion**.

Stress Corrosion Cracking (SCC)

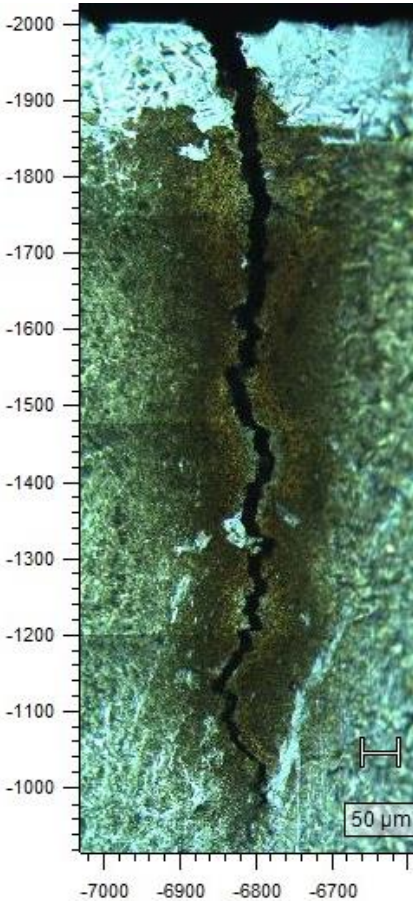

- ▶ SCC causes significant deterioration of component structural strength.
- ▶ It can occur **without any obvious outward signs** of damage accumulation.
- ▶ SCC is **difficult to predict**. Exact mechanisms not well understood.
- ▶ Requirement for techniques in which SCC can be imaged non-invasively **in situ** are of particular practical importance for the understanding of the physical mechanisms occurring.

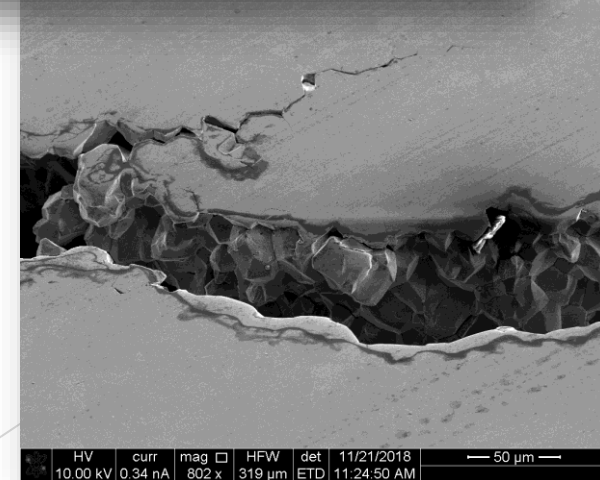

Stress Corrosion Cracking (SCC)

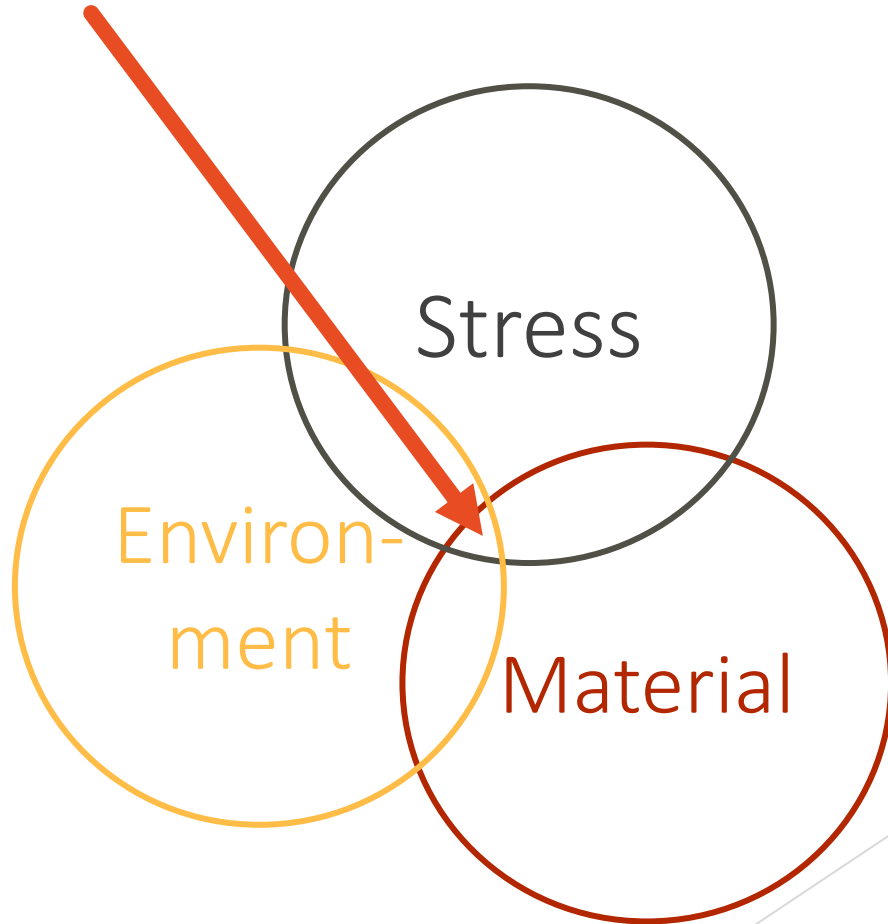

Material

- ▶ **Material:** Thermally sensitised (600°C for 70 hours) samples of AISI 304 stainless steel.
- ▶ Intergranular carbides seen in AFM data after surface preparation.
- ▶ Proxy material for stainless steel fuel cladding.

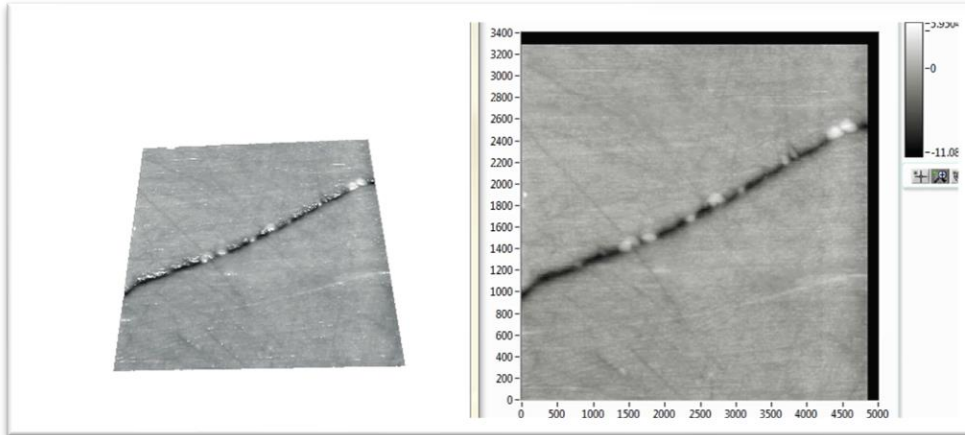
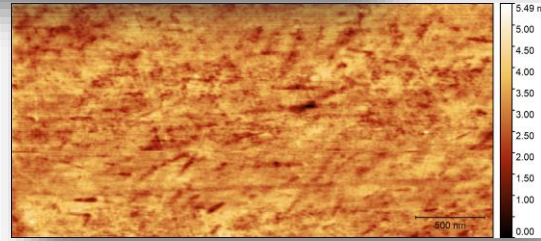
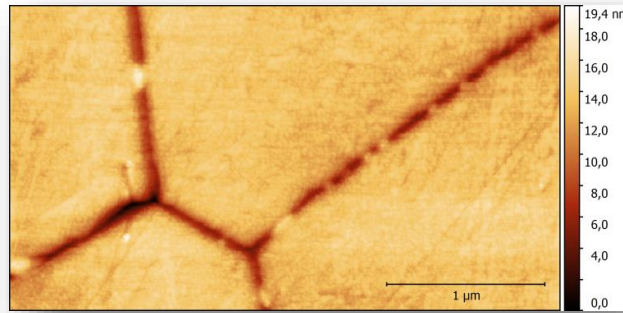

Stress Corrosion Cracking (SCC)

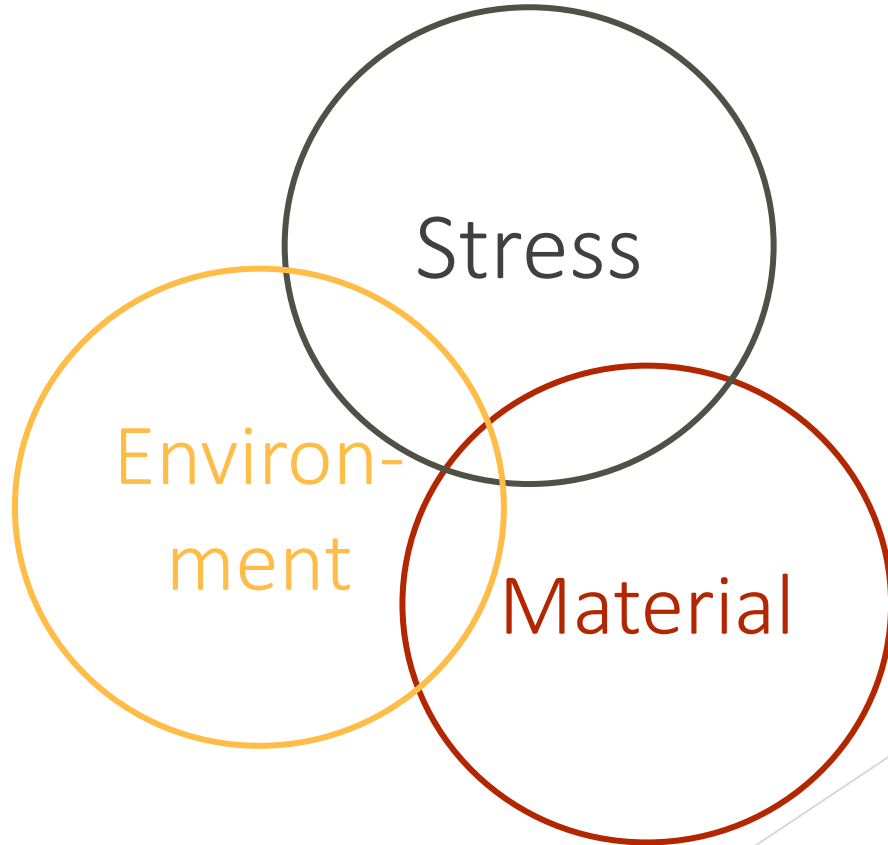

Environment

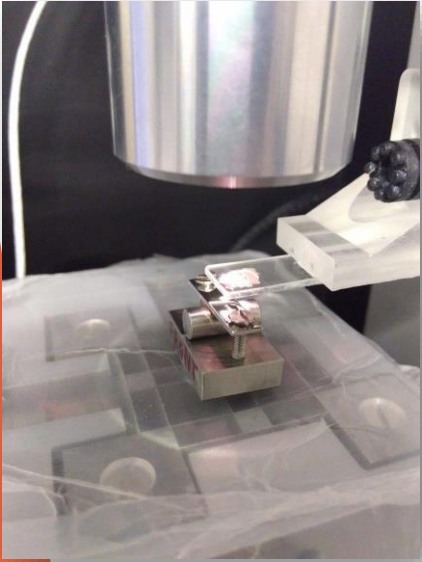

- ▶ **Corrosive conditions:** solution of 395 ppm sodium thiosulfate.
- ▶ Monitoring by HS-AFM in solution showed dissolution of carbides.

Environment

- ▶ Similar to that seen previously by Laferrere et al.
- ▶ Image below: Sensitised 20Cr-25Ni-Nb stabilised stainless steel under a droplet of deionised water with 5 ppm Cl⁻: (a) before, and (b) after polarisation.

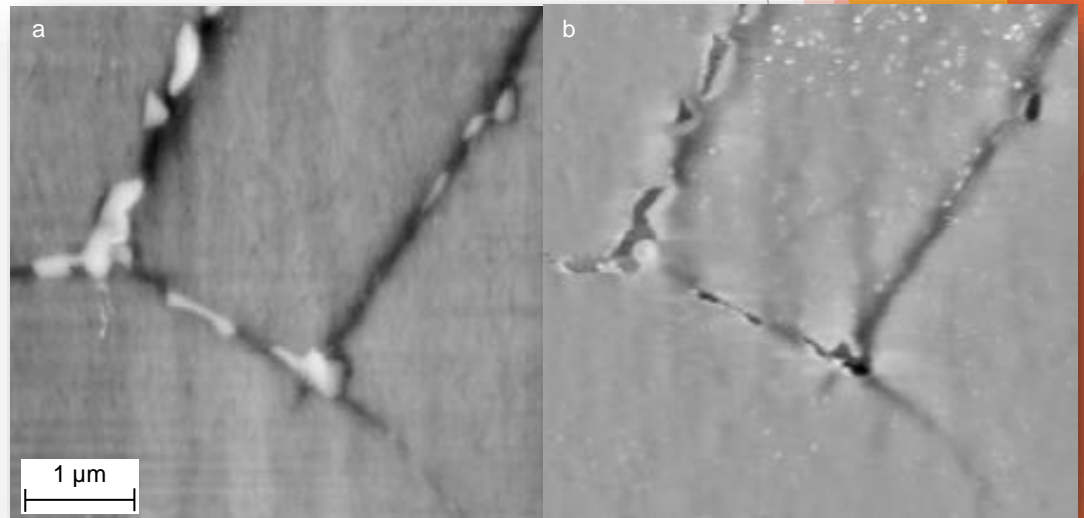

Stress Corrosion Cracking (SCC)

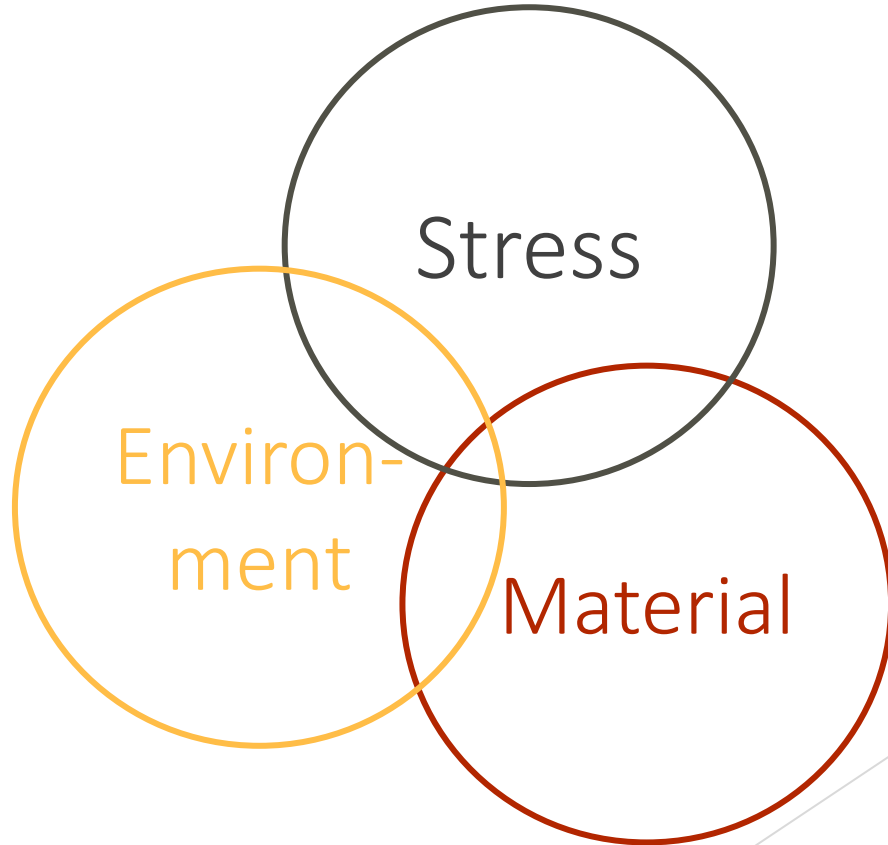

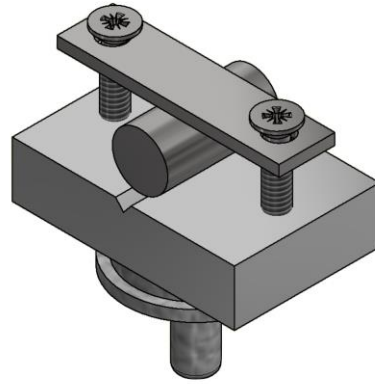
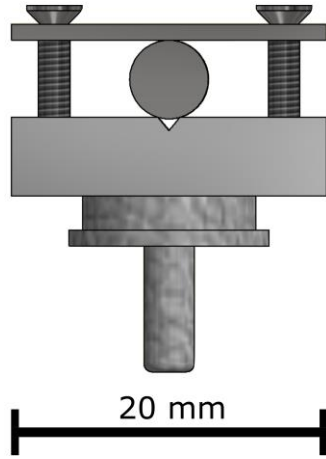

- ▶ **Stress:** Imparted to the sample via a custom built micro three-point strain rig (constant deflection).
- ▶ Needs to be small, light, and sturdy.

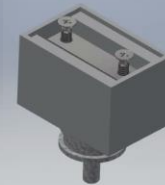
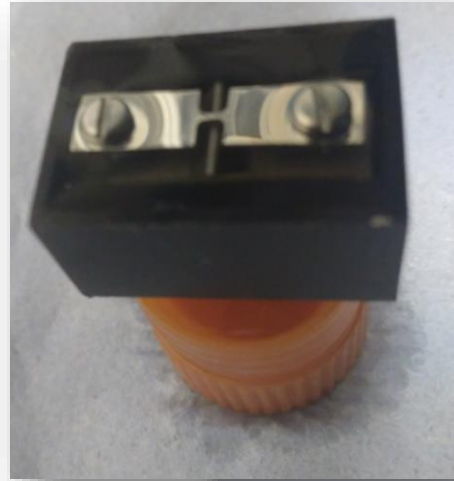

Stress Corrosion Cracking (SCC)

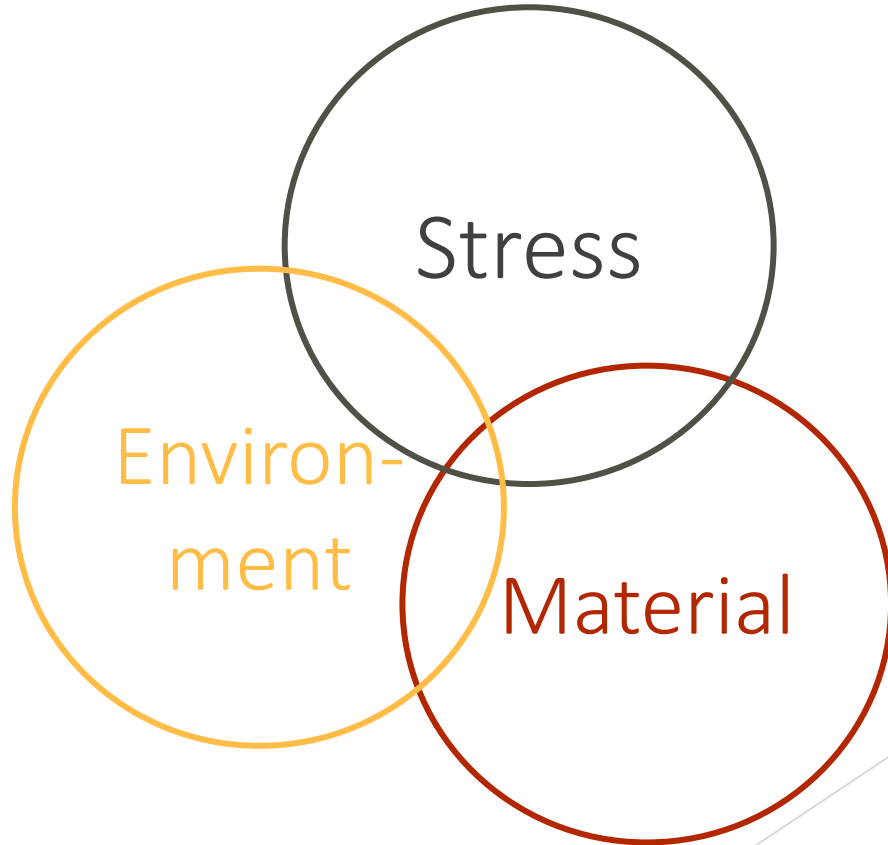

Optical Monitoring of SCC

- ▶ Suitability for HS-AFM may be evaluated by monitoring optically – Corrosion product on surface.
- ▶ SCC initiated in samples after a pre-exposure to the solution for 6 days. Sample then cracks typically within a day after stress is applied.

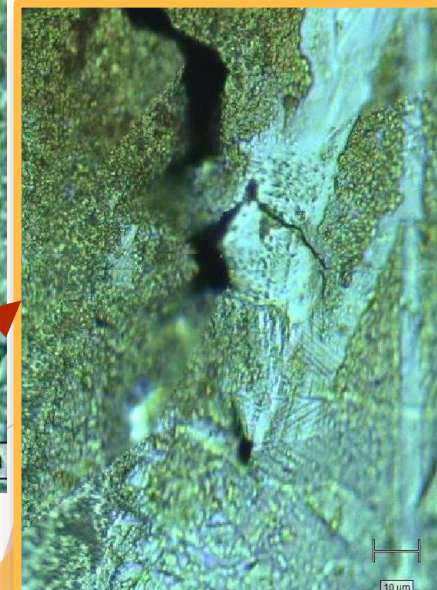
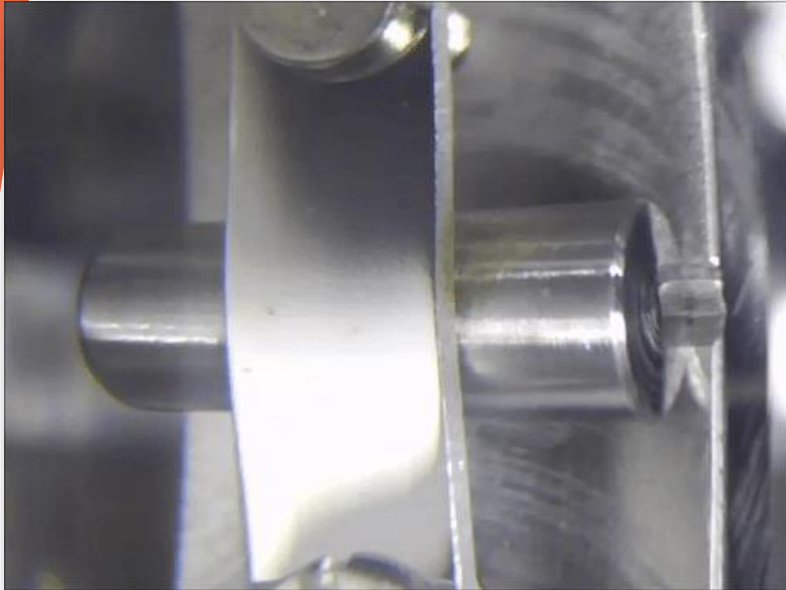

Ex-Situ HS-AFM of SCC

- ▶ Pre-cracked sample was dried and imaged by HS-AFM.
- ▶ Corrosion product on surface made imaging challenging.

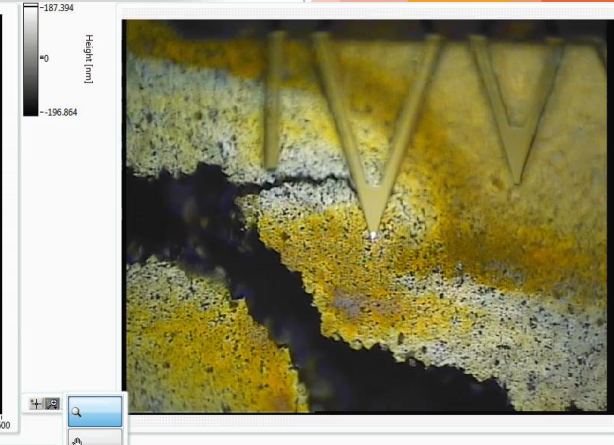
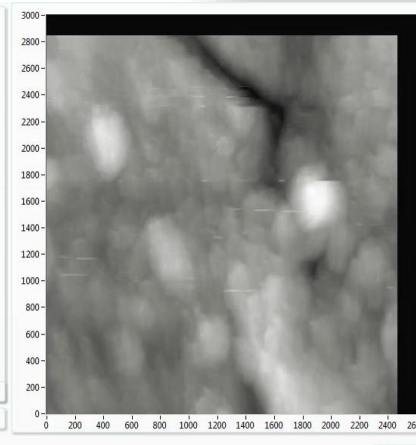
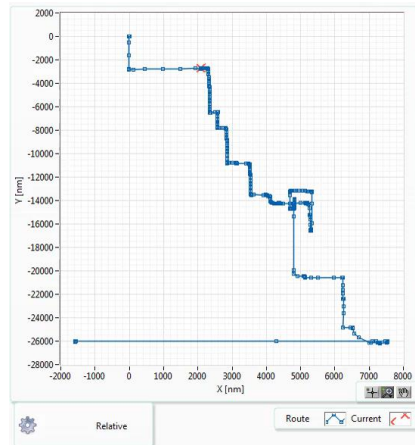
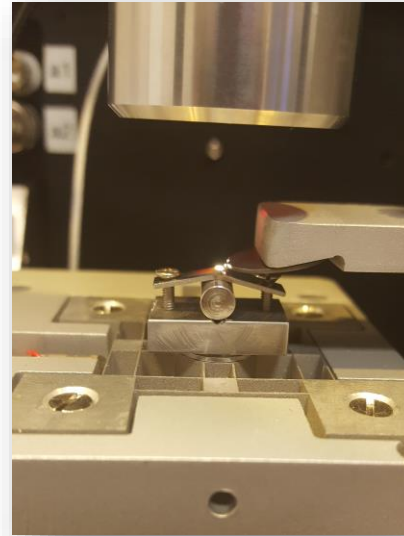

Ex-Situ HS-AFM of SCC

- ▶ Pre-cracked sample was dried and imaged by HS-AFM.
- ▶ Corrosion product on surface made imaging challenging.
- ▶ Sample was subsequently mounted and polished such that the surface was suitable for analysis.

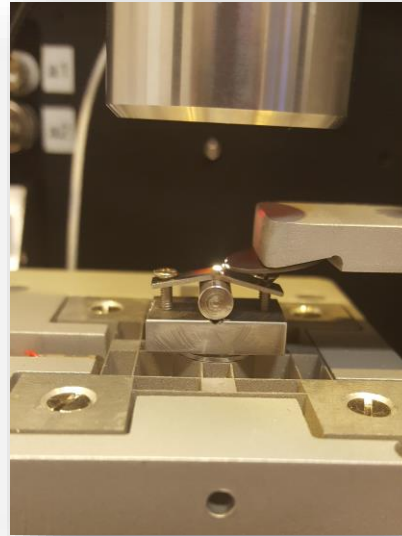

Ex-Situ HS-AFM of SCC

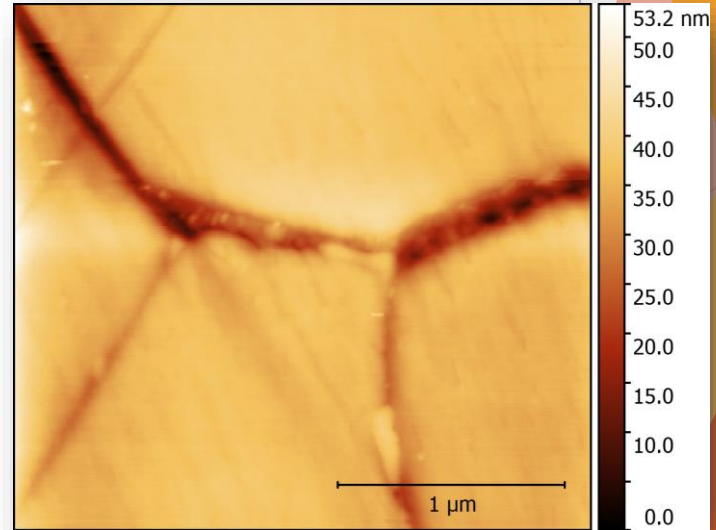
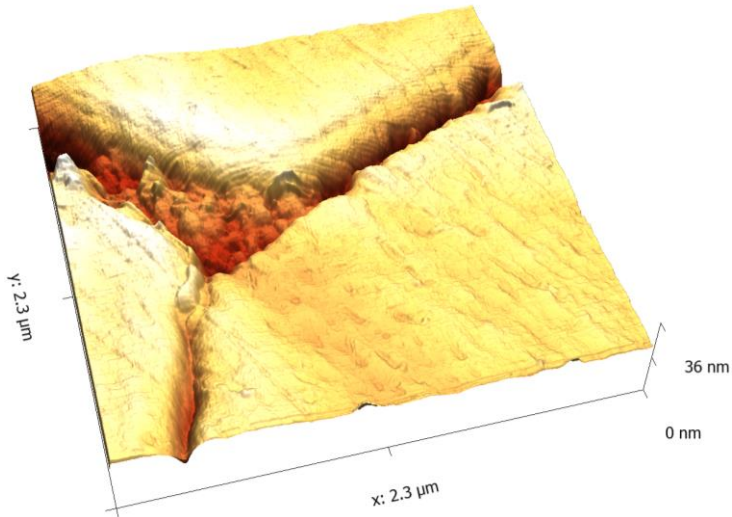
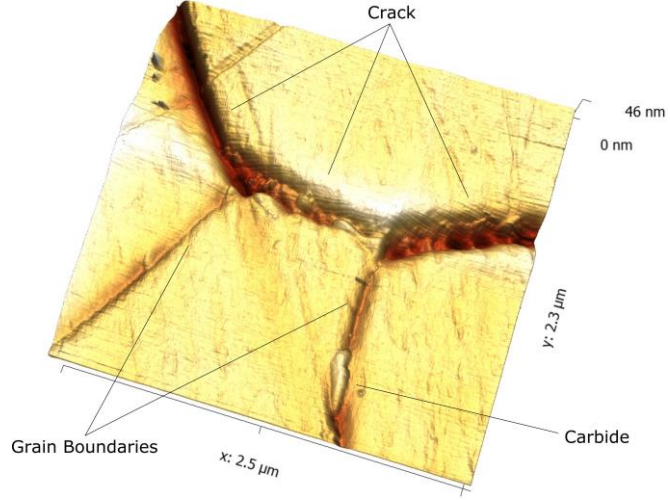

Ex-Situ HS-AFM of SCC

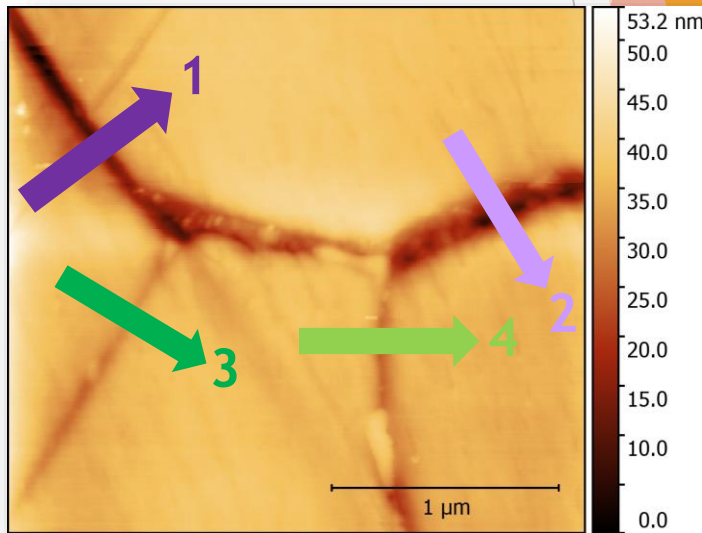
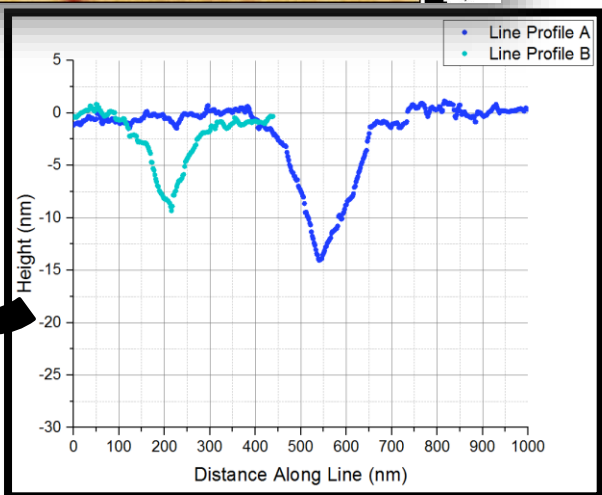
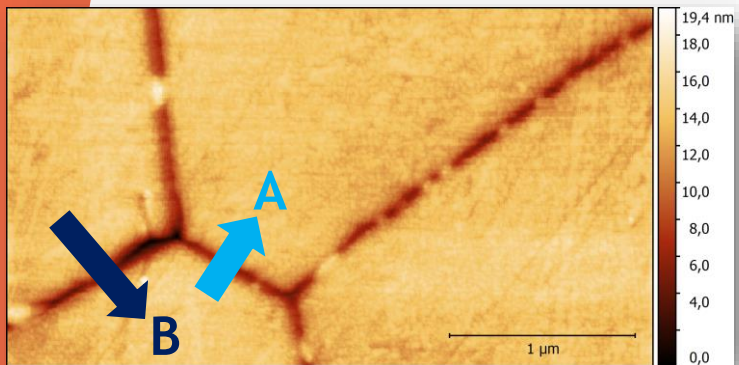
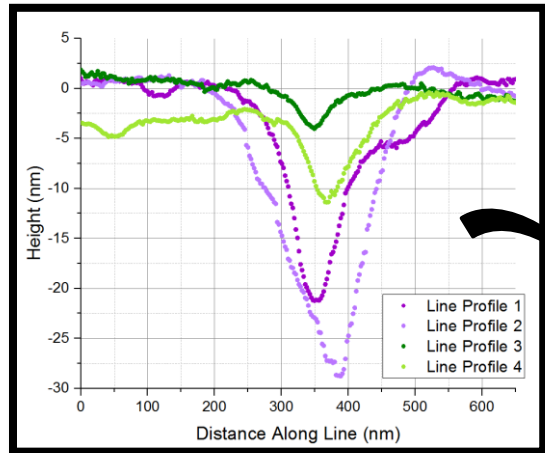

Ex-Situ HS-AFM of SCC

- ▶ Excellent basis for further experimentation.
- ▶ The results give a clear objective for what microstructures to look for that indicate SCC is taking place.

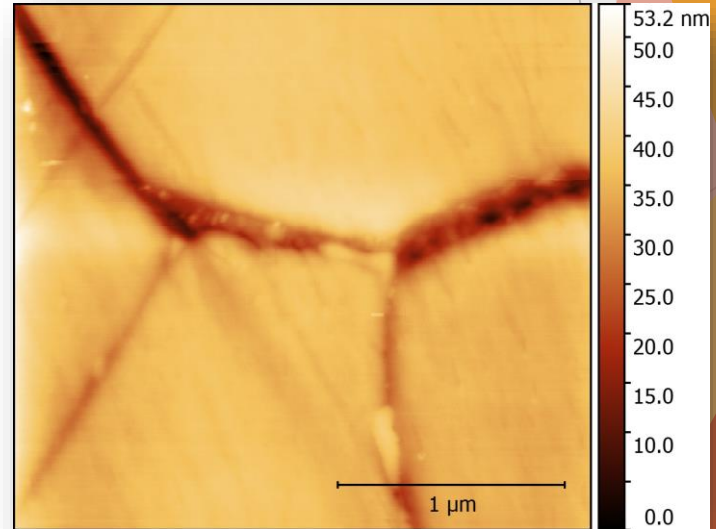
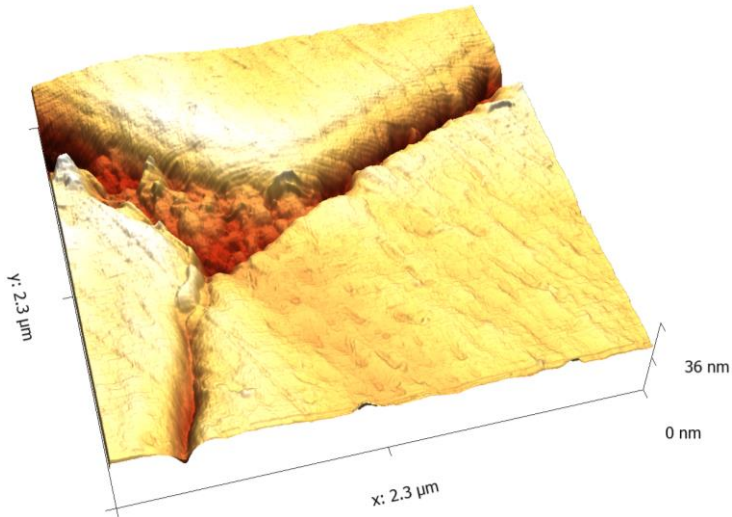
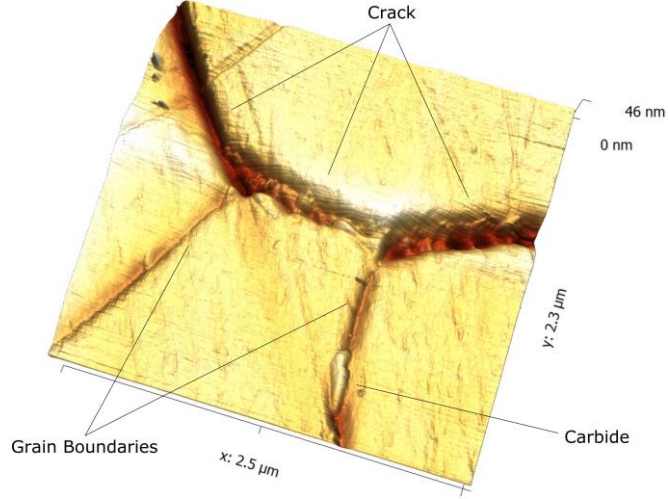

In-Situ HS-AFM of SCC

- ▶ We know how to set it up and what to look for.
- ▶ Challenging – Right place right time.
- ▶ Get ahead of crack tip and wait for propagation through frame.



Crack Propagation

- ▶ Area imaged as crack passed through the frame.
- ▶ Scans were performed across the sample to locate the cracked boundary.
- ▶ Optical images taken over duration of 15 minutes

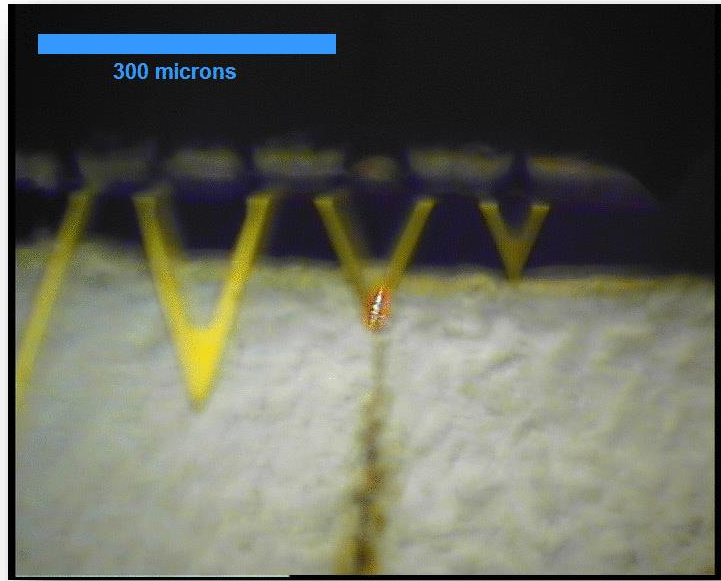

Crack Propagation – Before Failure

- ▶ HS-AFM measurements collected before cracking showed a raised GB that later cracked.
- ▶ Other GBs did not appear to be affected.

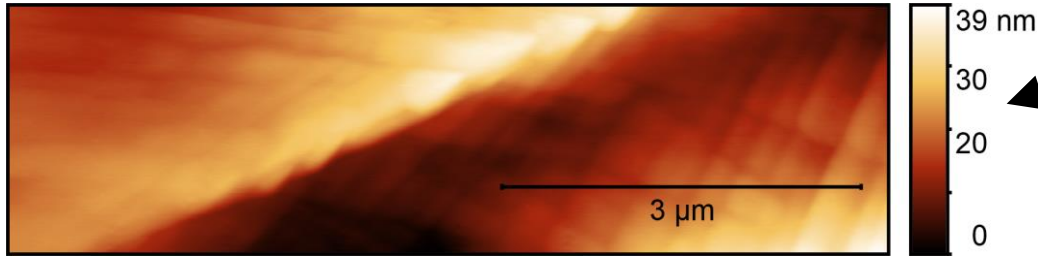

Results Thus Far

- ▶ HS-AFM measurements of SCC **seem** to show that:

GB → 'Uplift' → 'Rupture'

- ▶ HS-AFM can be difficult to interpret due to a myriad of reasons:
 - Tall sample causes 'letter box' effect.
 - Cracks are thin and deep – not great for cantilever.
 - Only seeing cross section as HS-AFM is a surface measurement.

Despite this, data is certainly promising, though needs to be explored further and methods refined.

Summary



The combined knowledge of stress corrosion cracking
Has been widely regarded as ultimately lacking
For the mystery of what happens on the nanoscale
Remains largely unknown, but time will tell

As technology progresses and new techniques are refined
Key mechanisms of SCC may soon be defined
But we must work together, this is what conferences are for
And with that, thank you for listening, and enjoy EuroCORR!

Thank You For Listening

Stacy Moore, Tomas Martin, Robert
Burrows, Loren Picco, Tom Scott, and
Oliver Payton
University of Bristol and NNL

stacy.moore@bristol.ac.uk